

MULTIPLE LOCKING SYSTEM EURO 5000 3.31.51XX.0



with profile-cylinder and 3 keys

Date of issue 05/2017 • All specifications are approximate • Errors and changes excepted
Product photos are for illustration purposes only

Available options:

- door thicknesses 52 - 60 mm, 72 - 80 mm, 82 - 90 mm, 92 - 100 mm, 102 - 110 mm, 112 - 120 mm, 132 - 140 mm, 152 - 160 mm
- electronic status indicator profile-cylinder
- electronic status indicator inside handle
- Locking System Euro 5000 single
- Locking System Euro 5000 single with latch



FEATURES

Operation angle	90°
Mounting	16 x Countersunk screw M5
Temperature range	-40°C up to +80°C
Cap	luminescent
Model	right hand and left hand mountable
Tested up to	200.000 cycles

MATERIALS & SURFACE

Housing, Cap	Plastic, dyed
Handle	Stainless steel
Gear rack	Stainless steel
Inside guide	Plastic, dyed
Outside guide	Zinc die-casting, plated
Conformity of the materials	all materials used are RoHS and REACH compliant

ASSEMBLY INSTRUCTIONS

3.31.51XX.0

ASSEMBLY

- 01 Insert the outside guide (Pos. 5) into the corresponding drill hole of the door and mount with 8x countersunk screws M5 on the door outer side. Depending on right or left version, attention must be paid to the marking „TOP RH“ or „TOP LH“ when installing the outer guide.
- 02 Insert the inside guide (Pos.6) into the corresponding drill hole of the door and mount with 8x countersunk screws M5 on the inside of the door. Depending on right or left version, attention must be paid to the marking „TOP RH“ or „TOP LH“ when installing the inside guide.
- 03 Turn the outside handle (Pos.1) 45° (to the right or left) to the vertical position completely and insert it into the outer guide (Pos.5). Return the handle to the vertical position. Now the outside handle (Pos.1) is secured against being pushed out.
- 04 Insert the stop bolt (Pos.3) into the inside handle (Pos.2), making sure the „RH“ and „LH“ positions are according to door position.
- 05 Position the pinion (Pos.7) on the inside handle (Pos.2) and insert the gear rack (Pos.8). Pay attention to the gear rack position of the slider (Pos.8).
- 06 Press the hexagon socket screw (Pos.10) with the washer (Pos.9) into the inside handle (Pos.2). The hexagon socket screw (Pos.10) must not be above the tolerance compensation (Pos.12) (Fig.1, Page 4).
- 07 Ensure that the tolerance compensation (Pos.12) is screwed back enough that the nose of the tolerance compensation (Pos.12) rests against the stop of the inside handle (Pos.2) (Fig.4, Page 4).
- 08 Position the inside handle (Pos.2) horizontally through the inner guide via the square shaft (Pos.4) of the outside handle (Pos.1). Press with slight pressure on the inner guide (Pos.6) so that there is no margin between the inside handle (Pos.2) and the inside guide (Pos.6).
- 09 Screw the hexagon socket screw (Pos.10) clockwise until the tolerance compensation (Pos.12) comes to rest on the square shaft (Pos.4) (Fig.2, Page 4).
- 10 Press in the hexagon socket screw (Pos.10) so that it strikes in the square shaft hole (Fig.3, Page 4).
- 11 Screw the hexagon socket screw (Pos.10) into the square shaft (Pos.4) and thereby secure the inside handle (Pos.2). When tightening the hexagonal screw (Pos.10), make sure that the side flanks of the hexagon head are horizontal so that the cap (iPos.11) can be clipped into the inside handle (Pos.2).
- 12 Then clip the cap (Pos.11) into the inside handle (Pos.2).

PROFILE CYLINDER REPLACEMENT

When changing the profile half cylinder, make sure that the locking lug is in 90° position (3 o'clock)

SAFETY NOTICE

For safety reasons a second person must be on the outside of the door when testing the emergency escape function with the door installed

ASSEMBLY INSTRUCTIONS

3.31.51XX.0

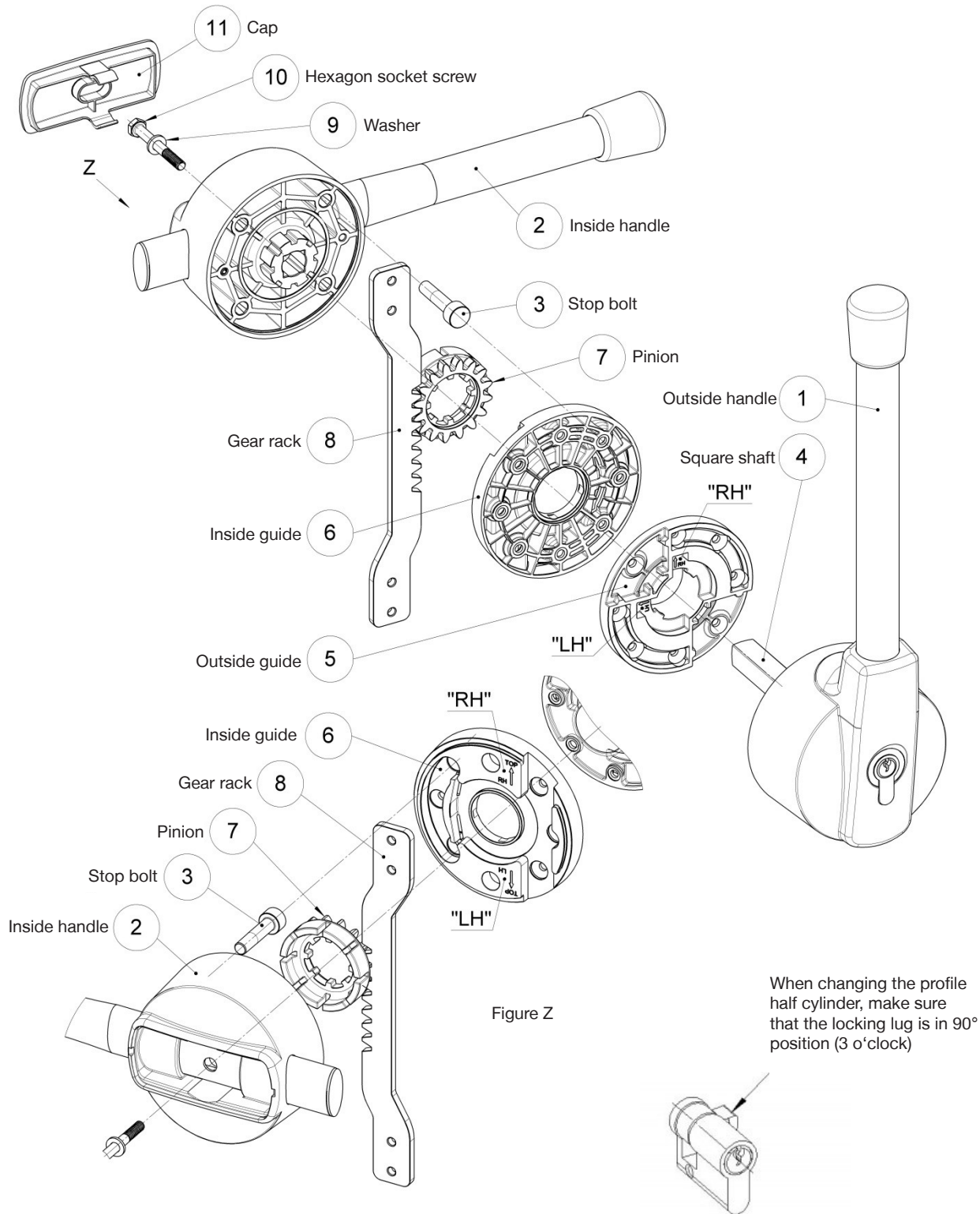
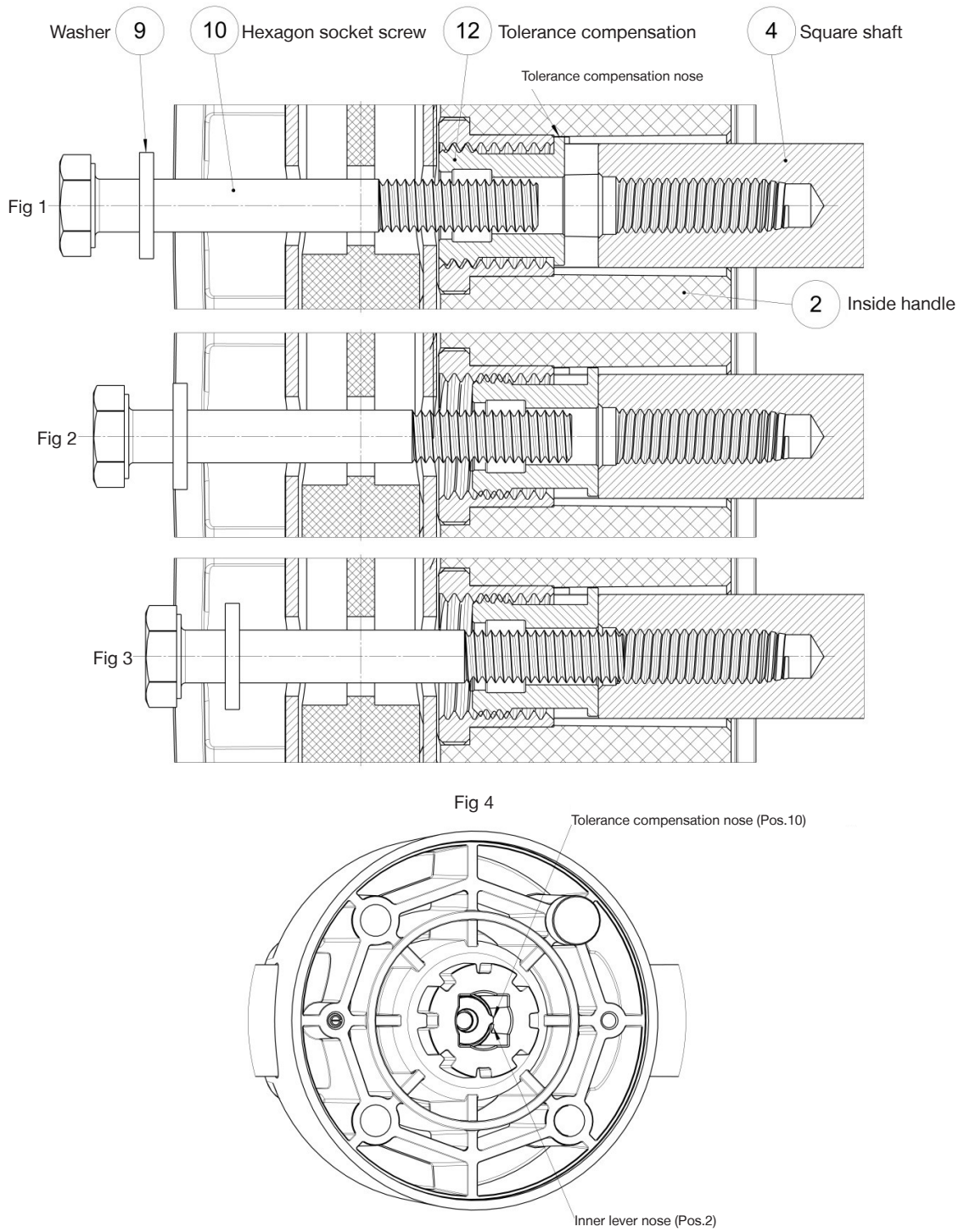

Figure Z

TOLERANCE COMPENSATION

3.31.51XX.0



DRILLING PATTERN

3.31.51XX.0

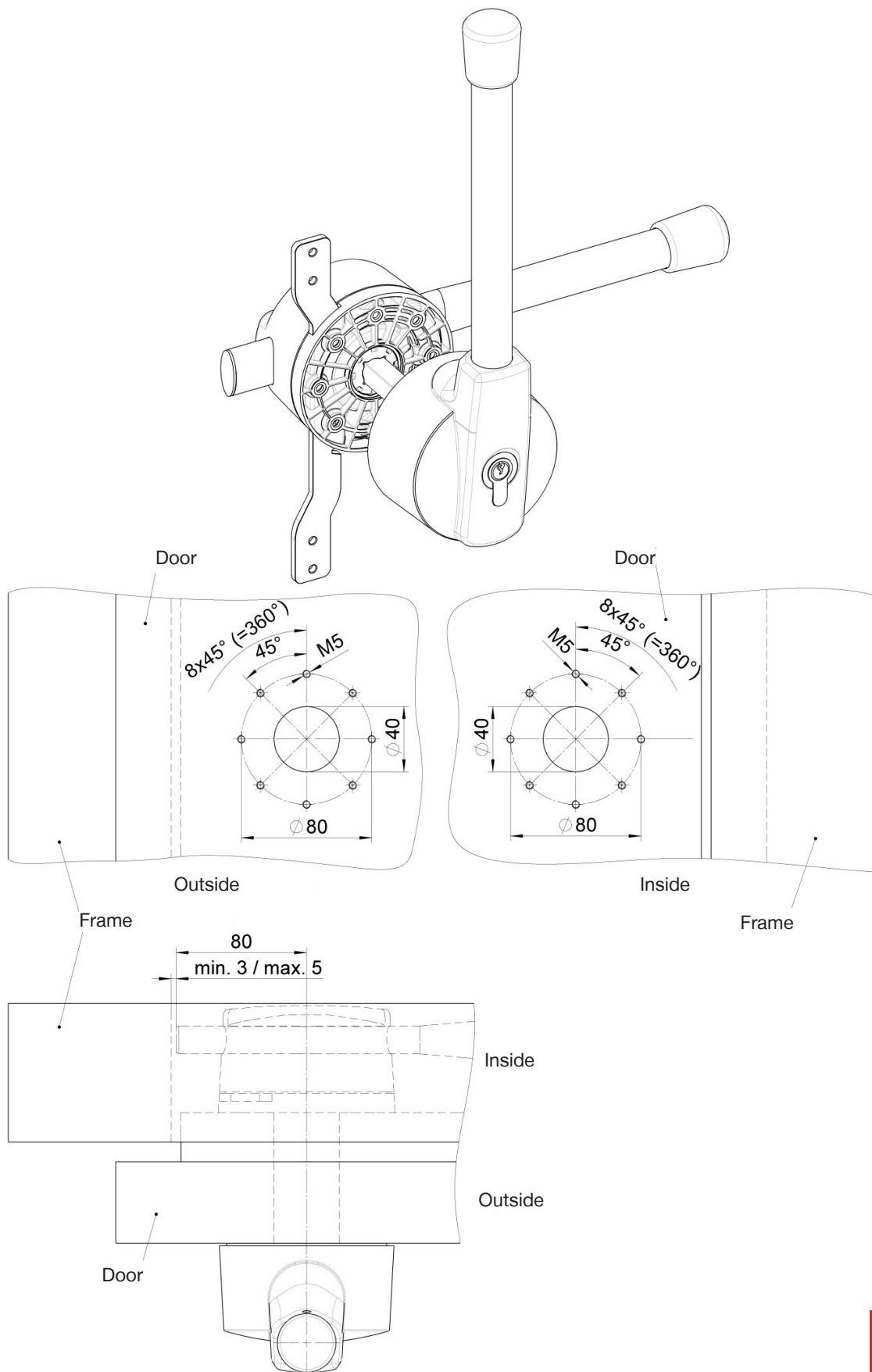

ROD CONNECTION

3.31.51XX.0

Rods not included

